

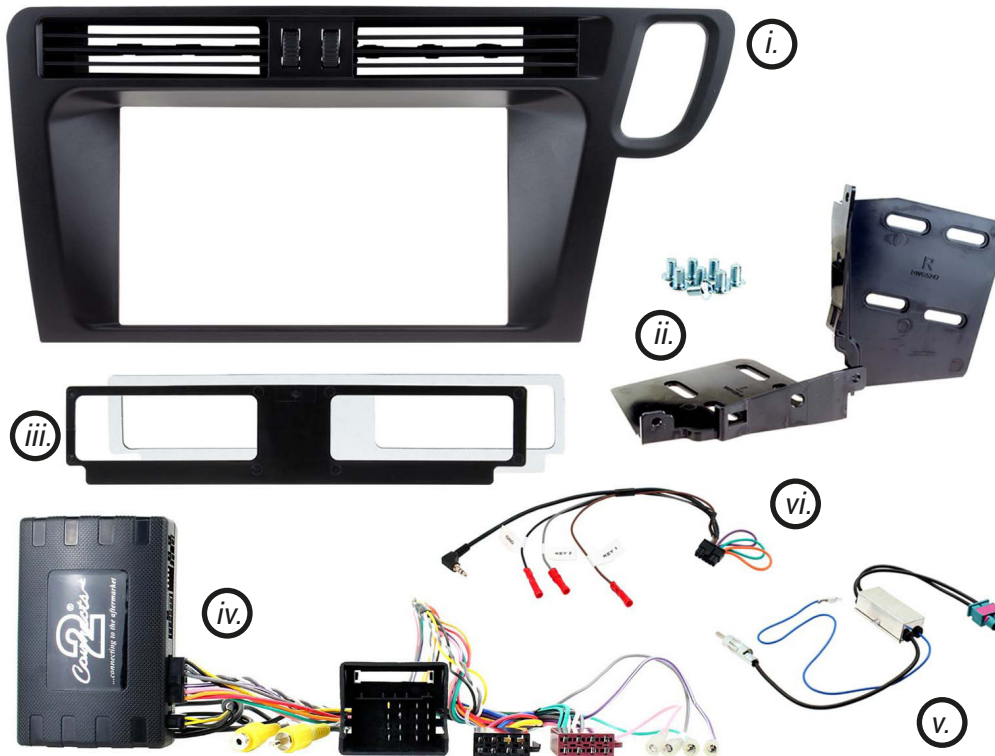

CTKAU19/L

Double DIN Installation Kit for Audi (Non-MMI) Vehicles



IN THE KIT

- i. Double DIN Fascia Panel*
- ii. Brackets & Hex Screws (8)
- iii. Airvent Bracket and Mount
- iv. Audi Infodapter
- v. Audi Antenna Adapter
- vi. Universal Patch Lead

*Note the fascia panel showcased throughout this instruction manual is for Right hand vehicles. The procedure is identical for Left hand vehicles, although you will need to use the CTKAU19L fascia panel during installation.

APPLICATION

Note: Application data is subject to change at any time

Audi Q5 (8R) 2008 - 2016

For basic Non-MMI systems only.

Note: vehicle will need modification. Please familiarise yourself with the instructions before undertaking installation.

RECOMMENDED TOOLS

- Panel Removal Tool
- Screwdriver
- 8mm Socket Wrench
- Cutting Tool

FEATURES

- Allows for the installation of a double DIN aftermarket stereo
- Includes mounting brackets and fitting accessories
- Retains vehicles settings, steering wheel and phone button functionality
- Generates settings menus, parking sensor audio and graphics
- Provides outputs for Park Brake, Reverse Gear, Speed Pulse and Mute

Need help? Visit support.connects2.com/tickets/technical

DISCLAIMER

The information provided in this document is subject to change without notice due to manufacturer changes and/or improvements to the product/s. This instruction manual is based on documented data and research. The manufacturer of this product cannot be held responsible for any changes made to the vehicle by the manufacturer or damages that may occur through the installation of this product in accordance with the steps outlined herein.

OVERVIEW DIAGRAM

RIGHT HAND DRIVE FASCIA ASSEMBLY

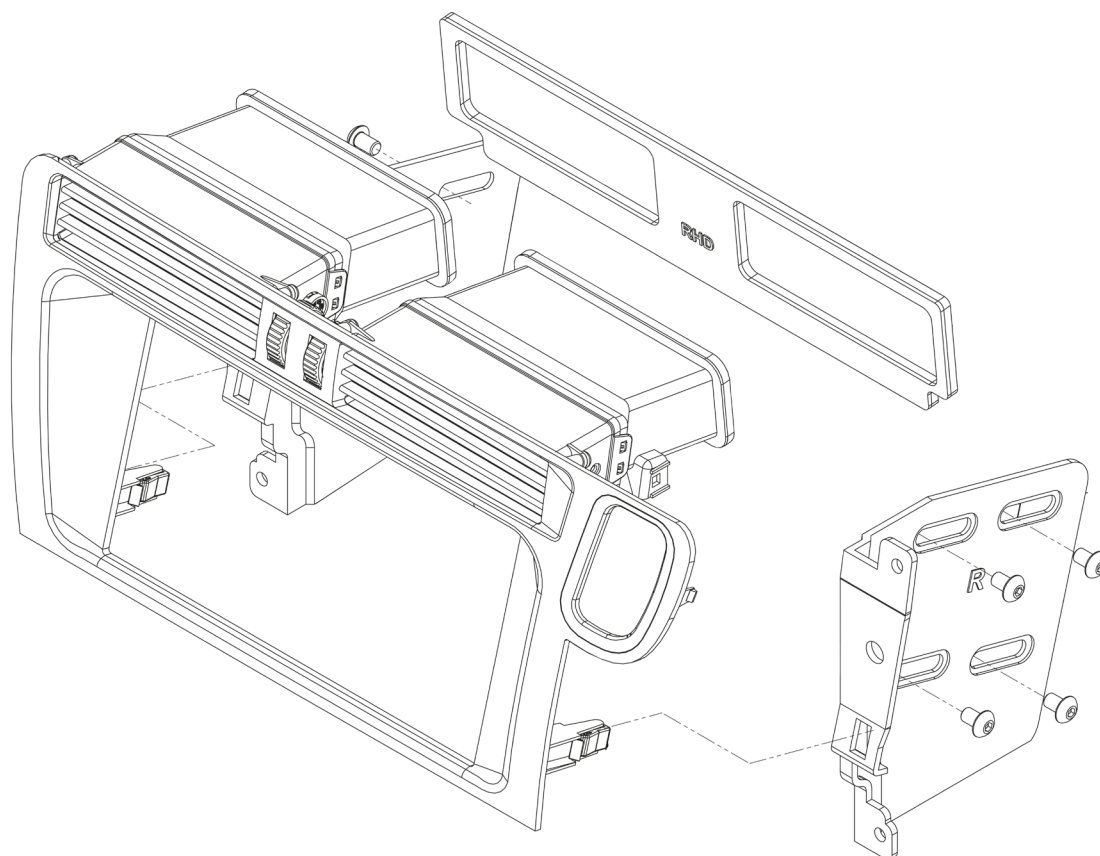

LEFT HAND DRIVE FASCIA ASSEMBLY

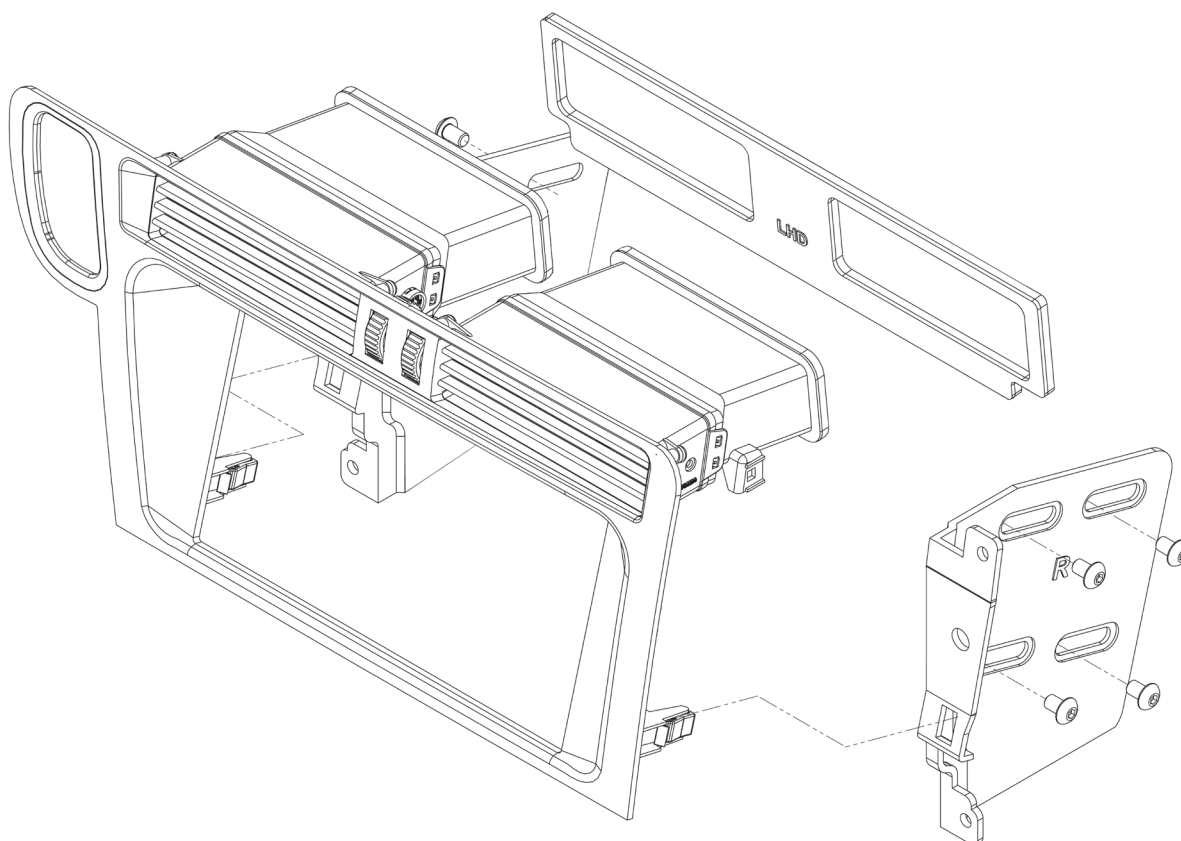

WIRING DIAGRAM

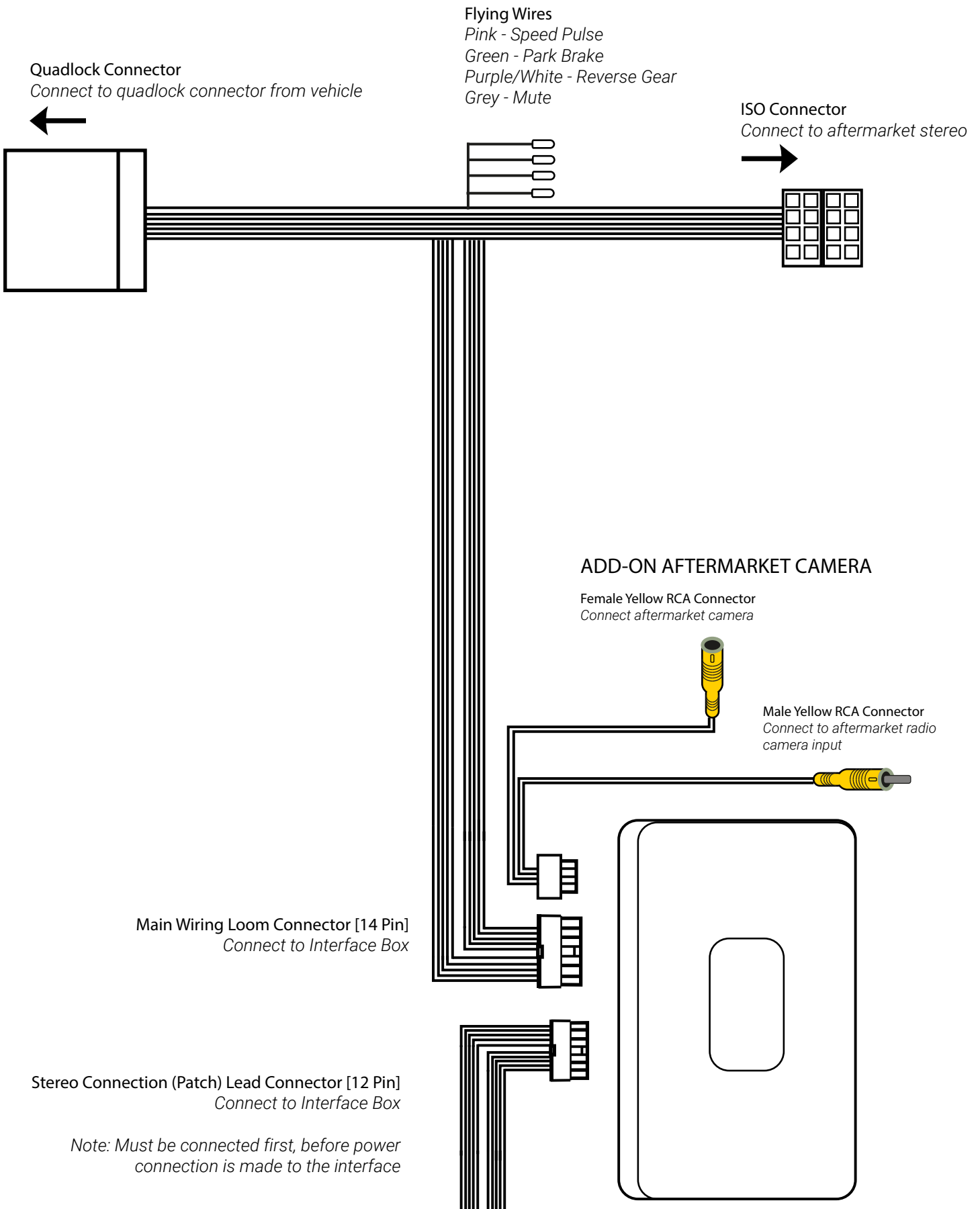

WIRING KEY

IN ISO CONNECTOR

Purple	Right Rear Speaker +	Yellow	Permanent 12V
Purple/Black	Right Rear Speaker -	Black	Ground
Green	Left Rear Speaker +	Red	Ignition 12V
Green/Black	Left Rear Speaker -	Orange	Illumination
Grey	Right Front Speaker +		
Grey/Black	Right Front Speaker -		
White	Left Front Speaker +		
White/Black	Left Front Speaker -		

ADDITIONAL CONNECTIONS

Purple/White	Reverse Gear	Yellow RCA (M)	Infodapter Display Video
Light Pink	Speed Pulse	Yellow RCA (F)	Connect Aftermarket Camera
Light Green	Park Brake		
Grey	Mute		

INTERFACE CONNECTIONS

- ① Reverse Camera Extension Harness Input
- ② Power Harness Input
- ③ Head Unit Connection (Patch) Lead Input
- ④ DIP Switch 1 - 'ON' for Pioneer, 'OFF' for other brand head units
 DIP Switch 2 - 'ON' for PAL reversing camera, 'OFF' for NTSC reversing camera (Default is 'OFF'/NTSC)
 DIP Switch 3 - Change from 'OFF' to 'ON' and back to reset screen settings to factory defaults.
Note: During this procedure, the screen background will change to red and no settings adjustments can be made.
 DIP Switch 4 - Not Used
- ⑤ Not used

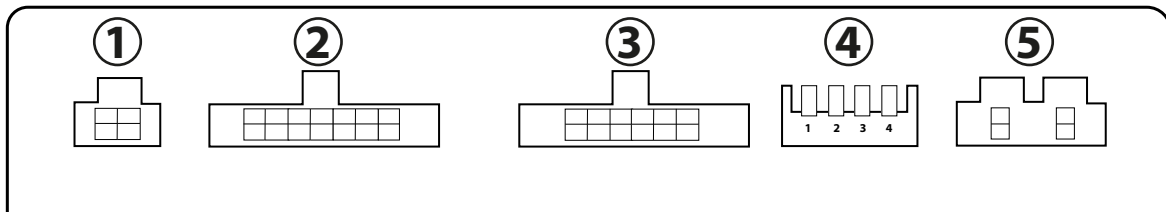

PRIOR TO INSTALLATION

Read the manual prior to installation. Technical knowledge is necessary for installation. The place of installation must be free of moisture and away from heat sources. Please ensure that the correct tools are used during the installation to avoid damage to the vehicle or product. **Connects2 can not be held responsible for the installation of this product.**

How to tell if your vehicle is 'MMI'



..... Audi with MMI



..... Audi without MMI

INSTALLATION GUIDE

DASH DISASSEMBLY

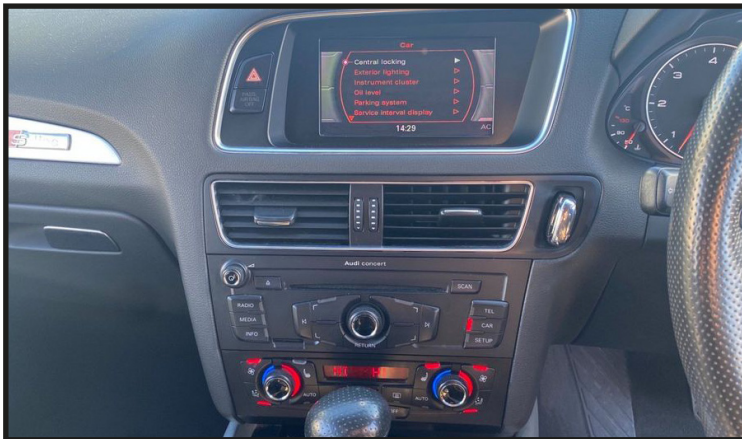

Audi Non-MMI OEM dashboard.

Ensure that appropriate areas of the dashboard are protected by a suitable material to avoid damage during installation.



Using a panel removal tool, pry away and unclip the bottom HVAC panel.

Once loose, disconnect the panel connectors and place to one side.



Using the panel removal tool again, begin to unclip the air vent panel. Due care and attention should be taken around the key port as this area is fragile. Once free, remove and place into storage.



Unscrew the four bolts that hold the head unit into place. Once free, remove the head unit whilst disconnect all the wiring.

In cases where there are no bolts, you will need to utilise a set of release keys to release the head unit.

INSTALLATION GUIDE

DASH MODIFICATION

4a

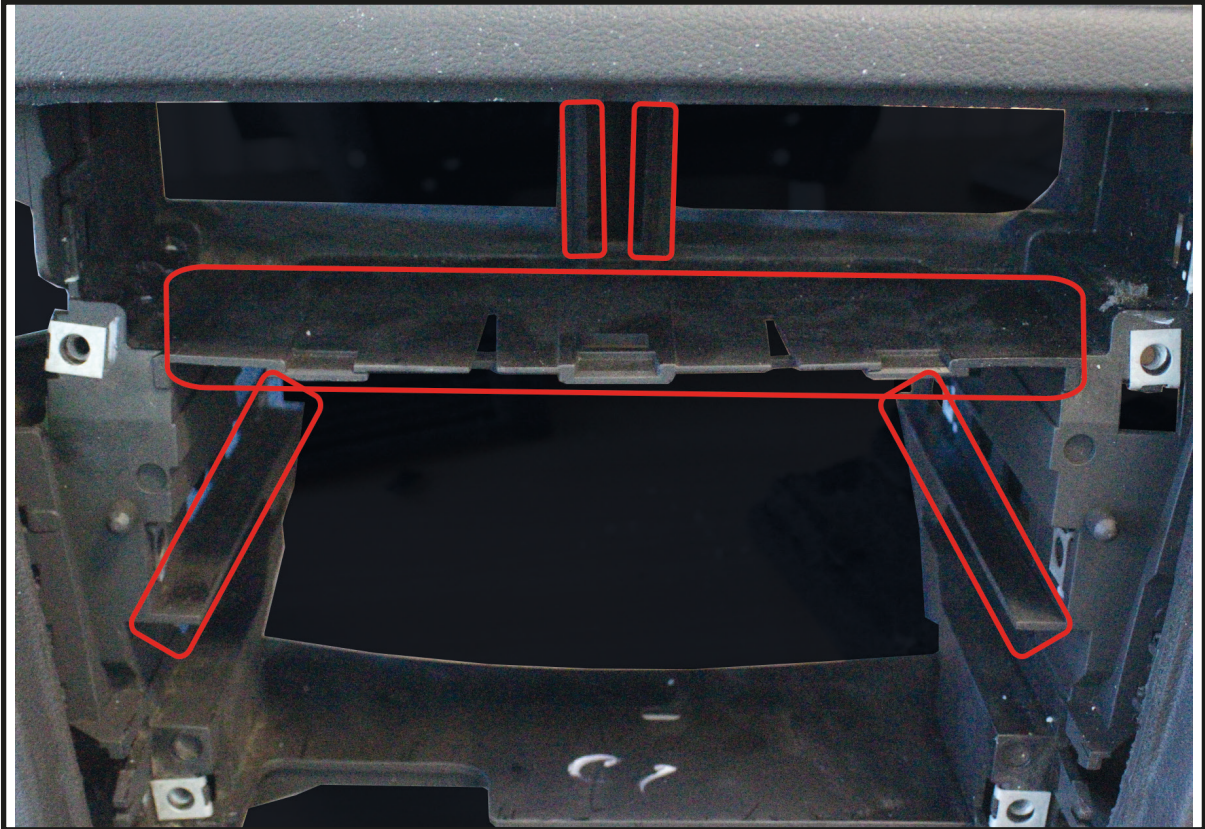

4b

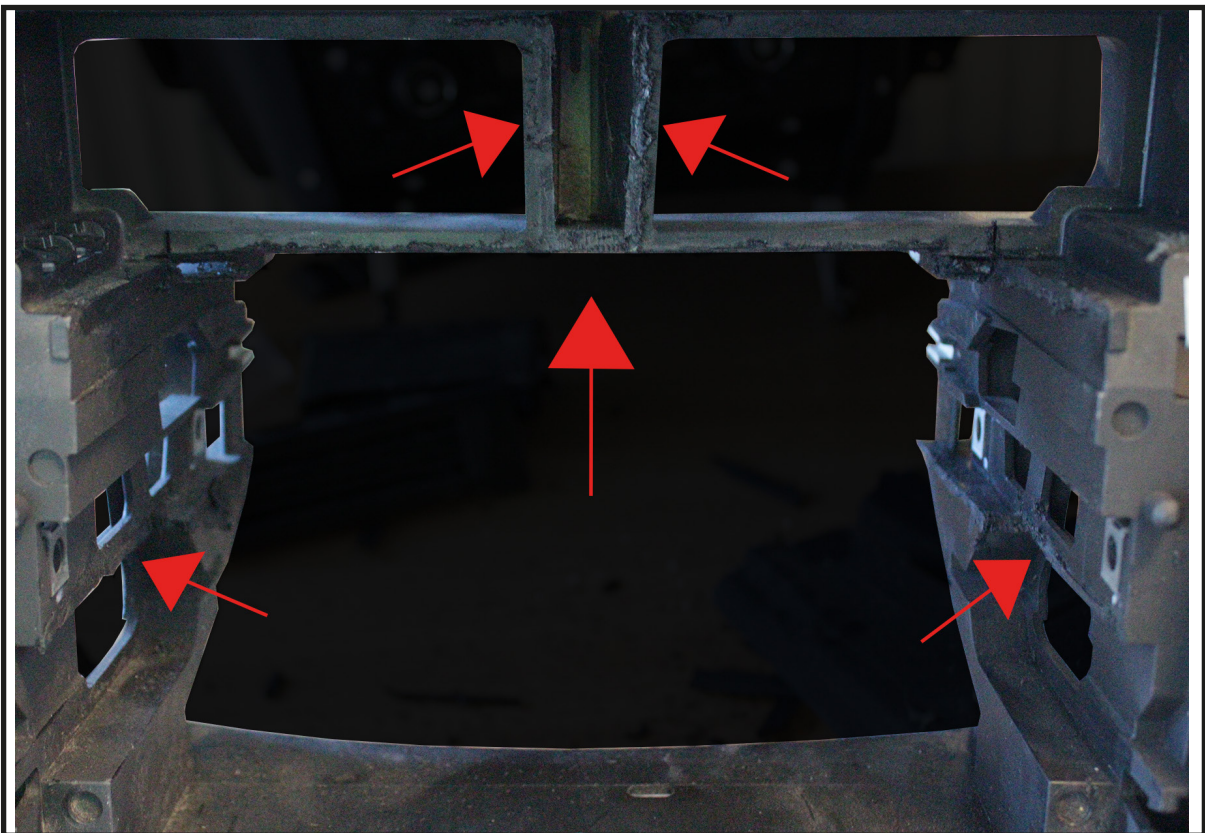

The highlighted sections of the dashboard will need to be cut in order for the new head unit to sit in place correctly.

When performing any modification to the vehicle, always ensure to measure where the stereo will sit and take due care when performing modifications to the vehicle.

Connects2 always promotes the use and expertise of professional installers. Connects2 will not be held responsible for any damage to the vehicle.

INSTALLATION GUIDE

KIT ASSEMBLY



The 'airvent bracket' will need to be placed into the dashboard with the appropriate side facing outward i.e. if working on a right hand drive vehicle, the side facing you would read "RHD".

Once you have selected the correct orientation, attach the dual sided foam mount to the back of the 'airvent bracket' and place into the vehicle.

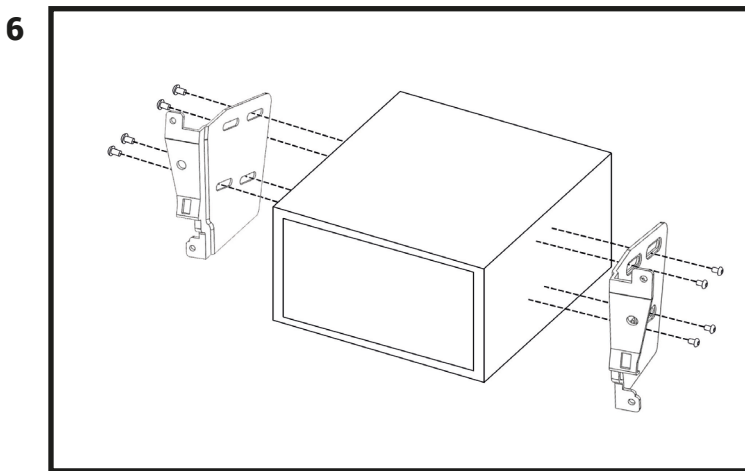

Attach the new Double DIN Brackets to the aftermarket head unit utilising the screws within the kit.

7 Connect the 12-pin connector from the stereo connection (patch) lead to the interface box.

8 Connect the opposite end of the stereo connection (patch) lead to the steering wheel control input on the back of the aftermarket stereo.

NOTE: This may be a 3.5mm jack connector or a wired input depending on the brand of aftermarket stereo being fitted. Please consult the aftermarket stereo installation manual for further information on where to make the connection.

IMPORTANT: THIS STEP MUST BE COMPLETED BEFORE CONNECTING POWER TO THE INTERFACE. FAILURE TO DO SO MAY RESULT IN A LACK OF FUNCTIONALITY AND THE NEED TO REINSTALL THE PRODUCT.

9 Connect the 14-pin connector from the supplied wiring loom to the interface box.

10 Connect the 4-pin camera extension harness to the interface box.

11 Connect the power/speaker ISO connector to the corresponding power/speaker ISO connector at the rear of the aftermarket stereo.

12 Connect flying wires from the main wiring harness to the head unit. See 'Additional Connections' on pg.3 for more information.

13 a) **To retain an OEM camera:** connect the yellow male RCA from camera extension harness to the reverse camera input of aftermarket head unit.

b) **To add an aftermarket reversing camera:** connect the yellow female RCA from camera extension harness to the male yellow RCA of aftermarket camera.

14 Connect the quadlock connector on the supplied harness to the quadlock connector from the vehicle.

INSTALLATION GUIDE

KIT ASSEMBLY

15 Test stereo and steering wheel control functionality for correct operation. If steering wheel control functions are unresponsive, please uninstall the interface and wiring and reinstall carefully in accordance with the above steps.

16



After testing is successful, begin to install the aftermarket head unit into the dashboard and use the pre-existing screws to screw into place.

Take the new fascia and place it over top and firmly press down around the edges to ensure it clips into place - reassemble the dashboard in reverse order to complete the installation.

For further help, please contact and fill out a support ticket with the full details of your issue at:
support.connects2.com/tickets/technical

USER GUIDE

STEERING WHEEL CONTROL FUNCTIONALITY

The following diagram, though based on careful research, is an example only. Individual steering wheel control configurations may differ.

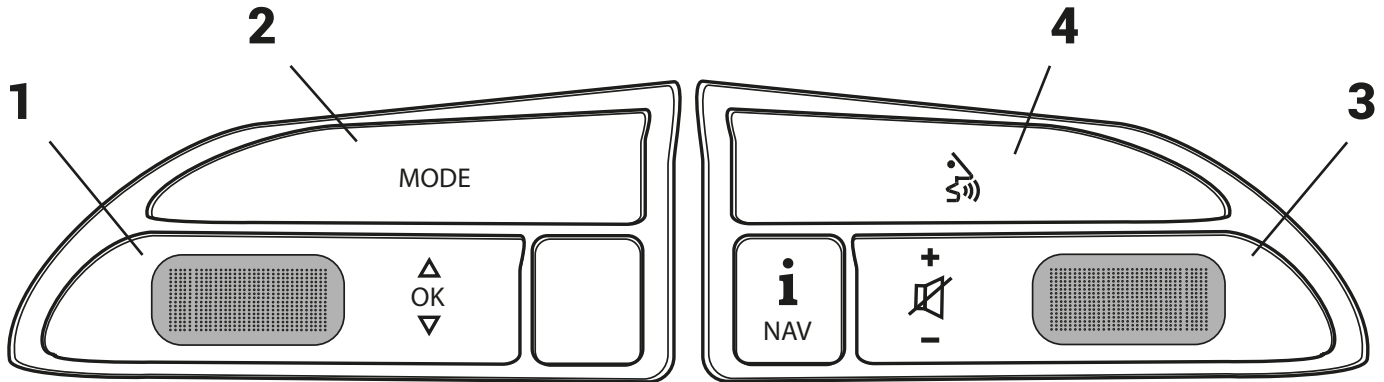

In Normal Mode

- | | |
|---|--|
| <ol style="list-style-type: none">1. Track + (Scroll Up)
Track - (Scroll Down)
Source (Short Press)
Enter Infodapter Menu (Long Press)2. Source (Short Press)
Enter Infodapter Menu (Long Press) | <ol style="list-style-type: none">3. Volume + (Scroll Up)
Volume - (Scroll Down)4. Pick Up (Short Press)
Hang Up (Long Press) |
|---|--|

In Infodapter Menu

- | | |
|---|--|
| <ol style="list-style-type: none">1. Menu Up (Scroll Up)
Menu Down (Scroll Down)
Select Menu Item (Short Press)2. Select Menu Item (Short Press) | <ol style="list-style-type: none">3. Volume + (Scroll Up)
Volume - (Scroll Down)4. Pick Up (Short Press)
Hang Up (Long Press) |
|---|--|

To exit the Infodapter Menu, select 'EXIT'

INFODAPTER MENU

Please be aware that whilst we retain most of the original vehicle features with our interfaces, some features may be lost. As we continue our research, this product can be updated to support even more OEM functionality.

Currently, this interface supports the following features: Language, Temperature, Time Format, Date Format, Tyre Pressure, Distance Units, Speed Units, Suggested Gear Change, Speed Warning, Board Computer 1/2, Auto Headlights, Leaving Home, Come Home Light Time, Daytime Running Lights, Head Lamp Conversion, Unlock Single Door, Auto Locking, Boot Lid and Tailgate, Parking Volume Front/Rear, Parking Freq Front/Rear, Oil Check, Service Due, Rain Sensor, Window Convenience Open Front/Rear, Windscreen Wiper Service Position.

USER GUIDE

INFODAPTER MENU

Press and hold either **Button 1** or **Button 2** to enter the Infodapters “Configuration Menu”.

Here you are able to navigate through the various options and settings.

DRIVE SELECT SETTINGS

Individual / Comfort / Auto / Dynamic / Off Road / Efficiency

Select the desired drive mode from the list of options.

Note this menu is only valid if selected within the “Installer Menu”.

VEHICLE SETTINGS

Within this menu, you are able to alter vehicle settings that would have been lost if not for the Infodapter. Below is a list of what the Infodapter will currently retain*:

**Note: Although care has been taken to ensure the accuracy of this menu structure at the time of printing this document, sudden changes in software by the manufacturer or incompatibilities with the interface cannot be accounted for. Do not consider this list to be exhaustive.*

Unit Settings

- > Distance
- > Speed
- > Temperature
- > Tyre Pressure Units

Time/Date

- > Hours
- > Minutes
- > Years
- > Month
- > Day
- > Set Time Format
- > Set Date Format

Parking System

- > Display
- > Front Volume
- > Front Frequency
- > Rear Volume
- > Rear Frequency

Window & Wipers

- > Convenience Open Front
- > Convenience Open Rear
- > Wiper Service Position
- > Rain Sensors

Lights

- > Come Home Light Time
- > Leaving Home Lights
- > Auto Headlights
- > Daytime Running Lights
- > Headlamp Converter

Speed

- > Speed Warning
- > Speed Warning At
- > Suggested Gear Change

Central Locking

- > Unlock Single Door
- > Auto Locking
- > Boot Lid & Tailgate

Instrument Cluster

- > Engine Oil Level
- > Oil Service
- > Service
- > Board Computer 1
 - > Fuel Range
 - > Average Consumption
 - > Current Consumption
 - > Average Speed
 - > Driving Time
 - > Distance Travelled
- > Board Computer 2
 - > Fuel Range
 - > Average Consumption
 - > Current Consumption
 - > Average Speed
 - > Driving Time
 - > Distance Travelled

Configuration Menu

- Drive Select Settings
- Vehicle Settings
- Infodapter Settings
- Language
- Version
- < Back

Configuration Menu

- Drive Select Settings
- Vehicle Settings
- Infodapter Settings
- Language
- Version
- < Back

Configuration Menu

- Drive Select Settings
- Vehicle Settings
- Infodapter Settings
- Language
- Version
- < Back

USER GUIDE

INFODAPTER MENU

INFODAPTER SETTINGS

The “Infodapter Settings” menu contains parameters that can be selected to enhance/adapt the Infodapters layout and functionality.

Screen Size/Position

Allows the user to setup the Infodapter display screen to the exact/desired size of the aftermarket stereo being fitted.

Picture Settings

Allows the user to adjust the Brightness, Contrast and Saturation levels of the Infodapter menu/parking graphics.

Preferences

• **Park Assist Version**

Select according to the desired colour configuration of the park assist graphic displayed on screen.

• **Camera Connected**

Select ‘Yes’ if an optional camera is connected.

• **Drivers Position**

Select according to drivers orientation.

• **Reverse Priority**

Select which image (Camera or Park Assist) will be shown by default when reversing.

(Note: this option is only available when “Camera Connected” is set to ‘Yes’)

• **Park Brake Source**

Set output to activate when park brake is on (Brake), when speed is less than 3km/h (Speed) or to remain on at all times (Always On).

• **Restore Factory Settings**

Select Yes to return all Infodapter settings to factory defaults.

LANGUAGE & VERSION

The latter of the settings menu gives the user a selection of languages - English/German/French etc. - as well as the ability to view the current firmware history.

<u>Screen Size/Position</u>	
Horizontal Size	>
Horizontal Positon	>
Vertical Size	>
Vertical Positon	>
< Back	

<u>Picture Settings</u>	
Brightness	>
Contrast	>
Saturation	>
< Back	

<u>Preferences</u>	
Park Assist Version	0
Camera Connected	Yes
Drivers Position	Right
Reverse Priority	Camera
Park Brake Source	Speed
Restore Factory Settings	>
< Back	

<u>Language</u>	
English	
Deutsch	
Francais	
Nederlands	
Italiano	
Espanol	
< Back	

<u>Configuration Menu</u>	
Drive Select Settings	
Vehicle Settings	
Infodapter Settings	
Language	
Version	
< Back	

NOTES
