



*...connecting to the aftermarket*

## CTSBM011.2

### BMW Steering Wheel Control Interface

BMW Mini R53 with Harmon Kardon Amp Retention



Plug and Play



Phone Button Support



USB Updateable



Works with CAN-Bus



Park Brake



Ignition



Illumination



Speed Pulse

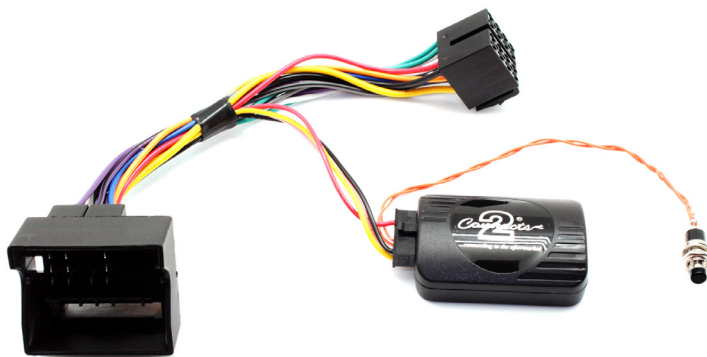

## INSTRUCTION MANUAL

*[www.connects2.com](http://www.connects2.com)*

Designed and  
Engineered  
in the UK. 

## ABOUT THIS PRODUCT...

---

### CTSBM011.2

BMW steering wheel control interface for BMW Mini R53 with Harmon Kardon Amp

#### Product Contents

- Interface
- Harness
- Instruction

#### Application

BMW Mini R53

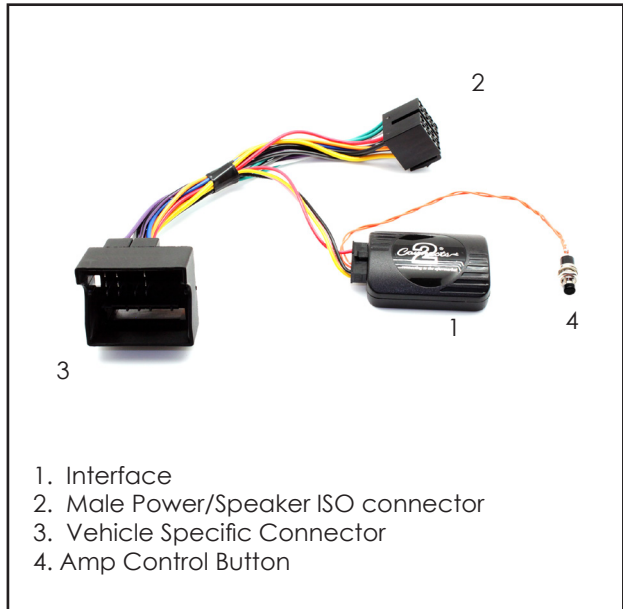

#### Prior to installation

Read the manual prior to installation. Technical knowledge is necessary for installation. The place of installation must be free of moisture and away from heat sources. Please ensure you use the correct tools to avoid damage to the vehicle or product.

**Connects2 can not be held responsible for the installation of this product.**

#### Technical Support

Connects2 want to provide a fast and suitable resolution should you encounter any technical issues. With this in mind, when contacting Connects2, try to provide as much Information as possible. This will speed up the process and help us to help you.

**Please use our dedicated online technical support centre: [support.connects2.com](http://support.connects2.com)**



Subscribe to our YouTube Channel for installation guides and tips... [www.youtube.com/connects2](http://www.youtube.com/connects2)

## FITTING GUIDE

---

1. Remove and disconnect the original head unit.
2. Connect the 12 way molex connector of the head unit patch lead (supplied separately) to the interface.

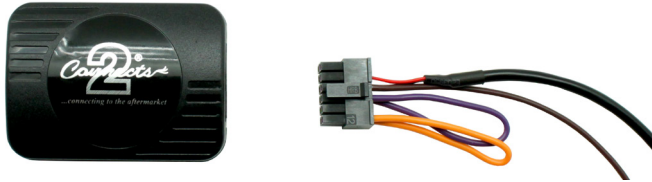

3. Connect the opposite end of head unit patch lead to the head unit steering wheel control input on the back of the aftermarket head unit. This may be a 3.5mm jack plug or a wire input depending upon the head unit brand being fitted. Please see the head unit installation manual for further information on where to connect.

**Important Note:** This step must be completed before connecting power to the interface. Failure to do so may result in no steering wheel control function.

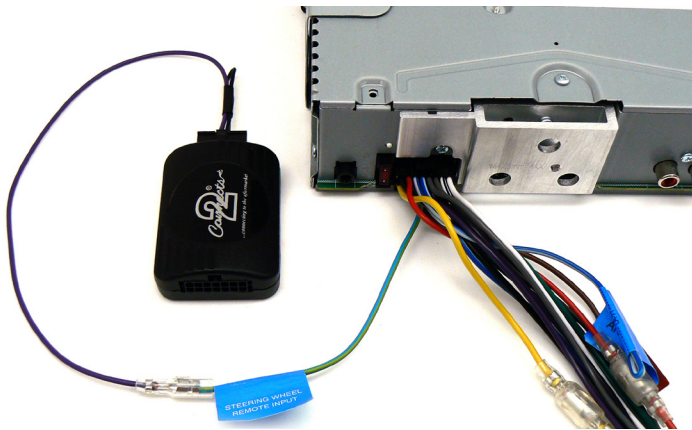

4. Connect the 14 way molex connector to the interface.



## FITTING GUIDE

---

5. For vehicles without source button, install control button on dashboard.



6. Connect the male power/speaker harness to the female power/speaker harness from the aftermarket head unit. Test head unit for correct operation.



## FITTING GUIDE

---

For aftermarket head units which do not have an ISO connector the interface uses the following wiring colours:

Wire Colour	Function
Yellow	Permanent 12V
Black	Ground
Red	12V Ignition
Orange	Illumination
Blue	Antenna Remote
Pink	Speed Pulse
Green	Park Brake
Purple	Reverse
Pink/Black	Telephone Mute

Wire Colour	Function
Purple	Right Rear Speaker +
Purple/Black	Right Rear Speaker -
Green	Left Rear Speaker +
Green/Black	Left Rear Speaker -
Grey	Right Front Speaker +
Grey/Black	Right Front Speaker -
White	Left Front Speaker +
White/Black	Left Front Speaker -

## STEERING WHEEL CONTROL FUNCTIONS

---

Steering Wheel Control Functions

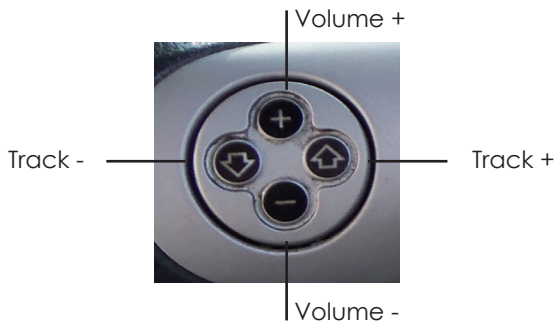

### **Operation for vehicles with steering wheel controls (vehicle must have Source button)**

To enter amplifier adjustment mode press and hold Source button for more than 3 seconds. When In amplifier adjustment mode the steering wheel controls no longer control the head unit.

### **Front/Rear Balance Adjustment**

Press & hold Vol + button to cycle from front to rear and back to front again. Release button when the desired setting is achieved.

### **Driver Mode**

To enable/disable Driver mode press Track +

### **Preset EQ**

Press Track – to cycle through Normal, Spacial, Electronic, Instrumental & Festival EQ settings.

To return the steering wheel controls to normal operation press Vol –

### **Operation for vehicles without steering wheel controls**

#### **Front/Rear Balance Adjustment**

Press & hold control button for more than 3 seconds to cycle from front to rear and back to front again. Release button when the desired setting is achieved.

#### **Driver Mode**

Press and hold control button for more than 1 second (but no longer than 3 seconds to avoid changing F/R Balance) to toggle Driver mode off/on

#### **Preset EQ**

A short press of the control button will change the various Preset EQ settings from Normal, Spacial, Electronic, Instrumental & Festival

#### **Save settings**

The interface will save all changes to its internal memory when the ignition is switched off. The settings will not be lost if power is disconnected.

