

OWNER'S MANUAL

RD 900/5

900W 5-Channel System Amplifier



NexD™
SWITCHING TECHNOLOGY

*Thank you for purchasing a JL Audio amplifier for
your automotive sound system.*

*Your amplifier has been designed and manufactured to exacting
standards in order to ensure years of musical enjoyment in your vehicle.*

*For maximum performance, we highly recommend that you have
your new amplifier installed by an authorized JL Audio dealer. Your
authorized dealer has the training, expertise and installation equipment
to ensure optimum performance from this product. Should you
decide to install the amplifier yourself, please take the time
to read this manual thoroughly to familiarize yourself
with its installation requirements and setup procedures.*

*If you have any questions regarding the instructions in this
manual or any aspect of your amplifier's operation, please contact your
authorized JL Audio dealer for assistance. If you need further assistance,
please call the JL Audio Technical Support Department
at (954) 443-1100 during business hours.*



PROTECT YOUR HEARING!

We value you as a long-term customer. For that reason, we urge you to practice restraint in the operation of this product so as not to damage your hearing and that of others in your vehicle. Studies have shown that continuous exposure to high sound pressure levels can lead to permanent (irreparable) hearing loss. This and all other high-power amplifiers are capable of producing such high sound pressure levels when connected to a speaker system. Please limit your continuous exposure to high volume levels.

While driving, operate your audio system in a manner that still allows you to hear necessary noises to operate your vehicle safely (horns, sirens, etc.).

SERIAL NUMBER

In the event that your amplifier requires service or is ever stolen, you will need to have a record of the product's serial number. Please take the time to enter that number in the space provided below. The serial number can be found on the bottom panel of the amplifier and on the amplifier packaging.

Serial Number:

INSTALLATION APPLICATIONS

This amplifier is designed for operation in vehicles with 12 volt, negative-ground electrical systems. Use of this product in vehicles with positive ground and/or voltages other than 12V may result in damage to the product and will void the warranty.

This product is not certified or approved for use in aircraft.

Do not attempt to "bridge" the outputs of this amplifier with the outputs of a second amplifier, including an identical one.

WHAT'S INCLUDED

- (1) RD900/5 amplifier
- (1) Round logo badge
- (1) 2.5 mm hex wrench
- (1) Owner's manual

PLANNING YOUR INSTALLATION

It is important that you take the time to read this manual and that you plan out your installation carefully. The following are some considerations that you must take into account when planning your installation.

Cooling Efficiency Considerations:

The outer shell of your JL Audio amplifier is designed to remove heat from the amplifier circuitry. For optimum cooling performance, this outer shell should be exposed to the largest possible volume of air. Enclosing the amplifier in a small, poorly ventilated chamber can lead to excessive heat build-up and degraded performance. If an installation calls for an enclosure around the amplifier, we recommend that this enclosure be ventilated with the aid of a fan. In normal applications, fan-cooling is not necessary.

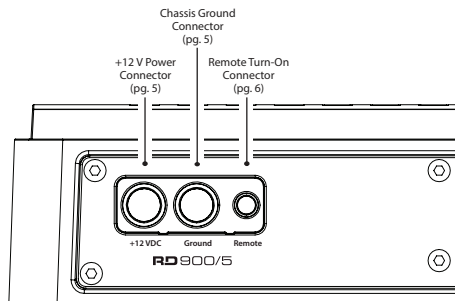
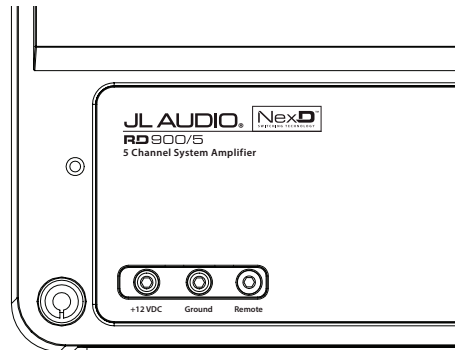

! IMPORTANT

Mounting the amplifier upside down is strongly discouraged. If mounting the amplifier under a seat, make sure there is at least 1 inch (2.5 cm) of space above the amplifier's outer shell to permit proper cooling.

Safety Considerations:

Your amplifier needs to be installed in a dry, well-ventilated environment and in a manner which does not interfere with your vehicle's safety equipment (air bags, seat belt systems, ABS brake systems, etc.). You should also take the time to securely mount the amplifier so that it does not come loose in the event of a collision or a sudden jolt to the vehicle.

Stupid Mistakes to Avoid

- Check before drilling any holes in your vehicle to make sure that you will not be drilling through a gas tank, brake line, wiring harness or other vital vehicle system.
- Do not run system wiring outside or underneath the vehicle. This is an extremely dangerous practice which can result in severe damage to your vehicle and person.
- Protect all system wires from sharp metal edges and wear by carefully routing them, tying them down and using grommets and loom where appropriate.
- Do not mount the amplifier in the engine compartment, under the vehicle, on the roof or in any other area that will expose the amplifier circuitry to the elements.

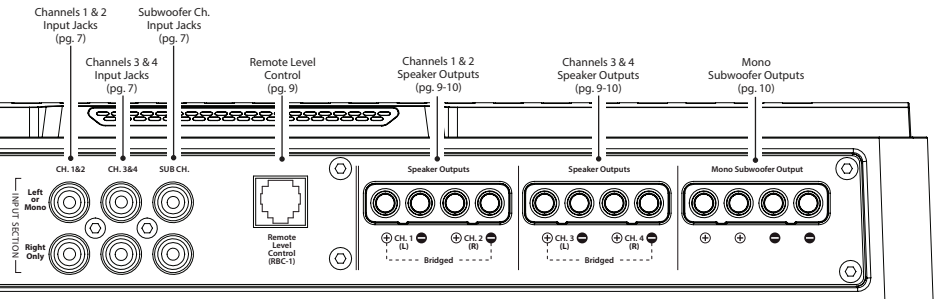
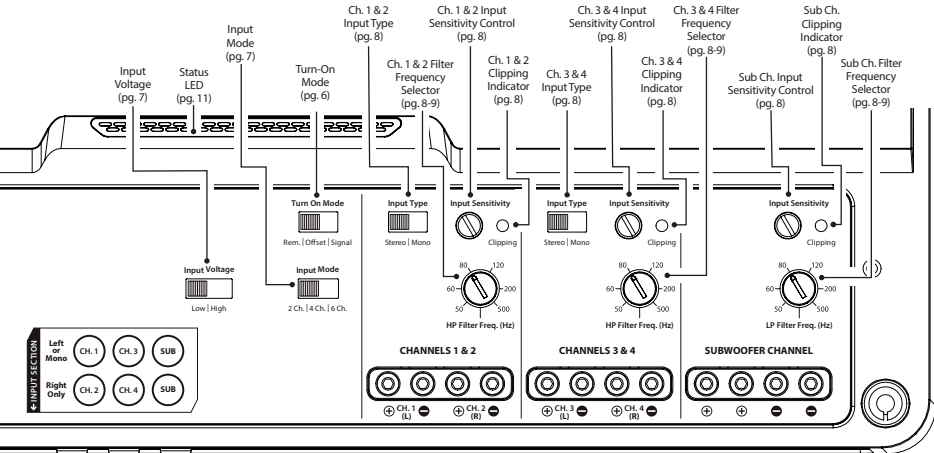

PRODUCT DESCRIPTION

The JL Audio RD900/5 is a five-channel, system amplifier utilizing JL Audio NexD™ ultra high speed switching technology for its four main channels and NexD™ high-speed switching for its subwoofer channel. The NexD™ technologies deliver outstanding fidelity and efficiency.

The RD900/5 can be operated with a wide variety of source units and system configurations.

TYPICAL INSTALLATION SEQUENCE

The following represents the sequence for a typical amplifier installation, using an aftermarket source unit or OEM Interface processor (like the FiX™ 82 or FiX™ 86). Additional steps and different procedures may be required in some applications. If you have any questions, please contact your authorized JL Audio dealer for assistance.

- 1) Disconnect the negative battery post connection and secure the disconnected cable to prevent accidental re-connection during installation. **This step is not optional.**
- 2) Run 4 AWG copper power wire from the battery location to the amplifier mounting location, taking care to route it in such a way that it will not be damaged and will not interfere with vehicle operation. Use 2 AWG or larger copper power wire and a fused power distribution block if additional amplifiers are being installed with the RD900/5.
- 3) Connect the power wire to the positive battery post. Fuse the wire with an appropriate fuse block (and connectors) within 18 inches (45 cm) wire length of the positive battery post. **This fuse is essential to protect the vehicle. Do not install the fuse until the power wire has been securely connected to the amplifier.**
- 4) Run signal cables and remote turn-on wire from the source unit to the final amplifier mounting location.
- 5) Run speaker cables from the speaker systems to the amplifier mounting location.
- 6) Find a good, solid metal grounding point close to the amplifier and connect the negative power wire to it using appropriate hardware (use of the JL Audio ECS master ground lug, XB-MGLU is recommended). Use 4 AWG copper wire, no longer than 36 inches (90 cm) from the amplifier to the ground connection point. In some vehicles, it may be necessary to upgrade the battery ground wire. (See page 5 for important notice).
- 7) Securely mount the amplifier and remove the top control panel cover using the supplied 2.5 mm hex wrench.
- 8) Connect the positive and negative power wires to the amplifier. A fuse near the amplifier is not necessary if the RD900/5 is the only device being run from the fused main power wire. If the fused main power wire is shared by the RD900/5 and other amplifiers or devices, fuse each amplifier/device within 12 inches (30 cm) of wire length, via a fused distribution block or multiple individual fuse blocks/on-board fuses.
- 9) Connect the remote turn-on wire to the amplifier or configure the “Turn-On Mode” switch for automatic turn-on.
- 10) Connect the input cables to the amplifier.
- 11) Connect the speaker cables to the amplifier.
- 12) Carefully review the amplifier’s control settings to make sure that they are set according to the needs of the system.
- 13) Install the power wire fuse (80A for a single RD900/5) and reconnect the negative battery post terminal. Install the fuse (80A) near the amplifier (if applicable).
- 14) Turn on the source unit at a low level to double-check that the amplifier is configured correctly. Resist the temptation to crank it up until you have verified the control settings.
- 15) Make necessary adjustments to the input sensitivity controls to obtain the right overall output and the desired balance in the system. See Appendix A (page 14) for the recommended input sensitivity setting method.
- 16) Replace the top control panel cover using the supplied 2.5 mm hex wrench.
- 17) Enjoy the fruits of your labor with your favorite music.

POWER CONNECTIONS

Before installing the amplifier, disconnect the negative (ground) wire from the vehicle's battery. This will prevent accidental damage to the system, the vehicle and your body during installation.

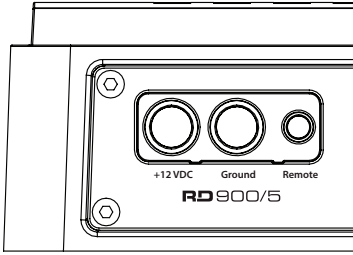

The RD900/5's “+12 VDC” and “Ground” connections are designed to accept 4 AWG copper power wire. **4 AWG is the minimum copper wire size for this amplifier.**

If you are installing the RD900/5 with other amplifiers and wish to use a single main power wire, use 2 AWG or 1/0 AWG main copper power wire (depending on the overall current demands of all the amplifiers in the system). This 2 AWG or 1/0 AWG power wire should terminate into a fused distribution block mounted as close to the amplifiers as possible (within 12 inches / 30 cm of wire length). The fused output of the distribution block will connect to the RD900/5 with 4 AWG power wire. JL Audio ECS fused distribution blocks are recommended (XD-FDBU-2 and XD-FDBU-4).

Note: Smaller AWG numbers mean bigger wire and vice-versa (1/0 AWG is the largest, 2 AWG is smaller, then 4 AWG, then 8 AWG, etc.).

To connect the power wires to the amplifier, first back out the set screw on the top of the terminal block, using the supplied 2.5 mm hex wrench. Strip 1/2 inch (12 mm) of insulation from the end of each wire and insert the bare wire into the terminal block, seating it firmly so that no bare wire is exposed. While holding the wire in place, tighten the set screw firmly, taking care not to strip the head of the screw.

The ground connection should be made using 4 AWG copper wire and should be kept as short as possible, while accessing a solid piece of sheet metal in the vehicle. The surface of the sheet metal should be sanded at the contact point to create a clean, metal-to-metal connection between the chassis and the termination of the ground wire. For optimal grounding, we recommend the use of a JL Audio ECS master ground lug (XB-MGLU). Alternatively, a sheet metal screw or bolt can be used with a star washer.

Any wires run through metal barriers (such as firewalls), must be protected with a high quality rubber grommet to prevent damage to the insulation of the wire. Failure to do so may result in a dangerous short circuit.

! IMPORTANT

Only use oxygen-free copper (OFC) wire or tinned copper wire for your amplifier's Power/Ground connections. Copper-clad aluminum (CCA) wire is not recommended.

! IMPORTANT

Many vehicles employ small (10 AWG - 6 AWG) wire to ground the battery to the vehicle chassis and to connect the alternator's positive connection to the battery. To prevent voltage drops, these wires should be upgraded to 4 AWG when installing amplifier systems with main fuse ratings above 60A.

FUSE REQUIREMENTS

It is absolutely vital that the main power wire(s) to the amplifier(s) in the system be fused within 18 inches (45 cm) of the positive battery post connection. The fuse value at each power wire should be high enough for all of the equipment being run from that power wire. If only the RD900/5 is being run from that power wire, use a 80A fuse.

If fusing the amplifier near its power connections (when more than one amp is being run from the main power wire), use a 80A fuse (MAXI™ big plastic-body fuse is recommended).

TURN-ON OPTIONS

The RD900/5 can be switched on and off using one of three methods, determined by the position of the amplifier's "Turn-On Mode" switch. Please read these options and decide which is best suited for your specific system.

- 1) +12V remote turn-on lead
- 2) DC offset-sensing turn-on circuit
- 3) Signal-sensing turn-on circuit.

+12V Remote Turn-On: This is the preferred method for turning the amplifier on/off. The amplifier will turn on when +12V is present at its "Remote" input and turn off when +12V is switched off. This +12V remote turn-on signal is typically controlled by a source unit or OEM interface processor's remote turn-on wire. The RD900/5's "Remote" turn-on connector will accept 18 AWG – 12 AWG wire. To connect the remote turn-on wire to the amplifier, first back out the set screw on the top of the terminal block, using the supplied 2.5 mm hex wrench. Strip 1/2 inch (12 mm) of wire and insert the bare wire into the terminal block, seating it firmly so that no bare wire is exposed. While holding the wire in the terminal, tighten the set screw firmly, taking care not to strip the head of the screw and making sure that the wire is firmly gripped by the set screw.

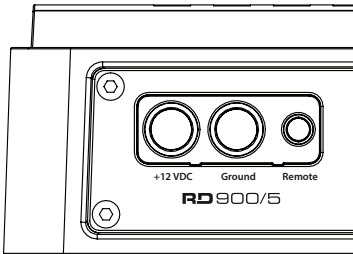

If a source unit does not have a dedicated remote turn-on output, consider one of the following alternative turn-on options:

These methods are useful when a conventional +12V remote turn-on signal is not available in a system. These allow you to operate the amplifier without having to locate a remote turn-on lead at the source unit, which can be very useful when interfacing the amplifier with OEM (factory) audio systems that do not use conventional +12V turn-on leads.

Depending on the characteristics of the audio signal, one of the following methods may work better than the other. We recommend trying DC Offset-Sensing first as it does not require a long delay to turn the system off after the signal is shut off.

DC Offset-Sensing: The amplifier will turn on and off by detecting the presence of a very small DC signal (offset) that is typical in the audio output of most OEM (factory) source units and amplifiers. The amplifier will turn on and off in reaction to the presence or absence of this DC Offset. The sensitivity of this circuit is designed for high-level (speaker level) signals, not for low-level (preamp level) signals. **The circuit senses the input signal from CH. 1 (L) only.**

Signal-Sensing: The amplifier will turn on and off by detecting the presence of a full-range audio signal. After approximately 30 seconds, the amplifier will shut off. The sensitivity of this circuit is designed for high-level (speaker level) signals, not for low-level (preamp level) signals. The circuit is tuned to react to signals at mid-range frequencies. This prevents false switching from signals created by moving loudspeakers that are in parallel with the amplifier's input signal. **The circuit senses the input signal from CH. 1 (L) only.**

INPUT SECTION

The RD900/5's input section allows you to send signals to the amplifier section through the use of two, four or six differential-balanced inputs.

Input connections are via three pairs of traditional RCA-type jacks.

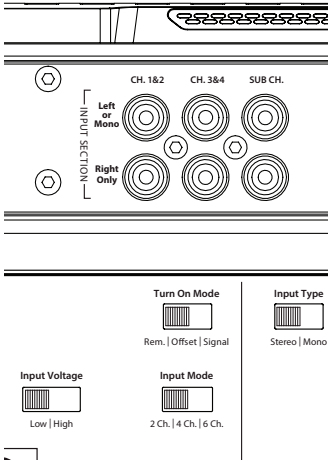

If you wish to send six discrete channels into the RD900/5, simply use all six inputs and set the “**Input Mode**” switch in the “**6 Ch.**” position. You may run a stereo or mono signal into the “**SUB CH.**” inputs of the amplifier. The amplifier’s subwoofer channel input section automatically sums stereo to mono for the internal amplifier section. If you have only one channel of subwoofer signal available, it is acceptable to only use one of the “**SUB CH.**” inputs, but for optimal gain, we recommend using a Y-adaptor and feeding both “**SUB CH.**” inputs.

If you prefer to use only four channels of input into the RD900/5, set the “**Input Mode**” switch in the “**4 Ch.**” position and use the Ch 1 & 2 and Ch 3 & 4 Inputs. In this mode, the RD900/5 will derive its subwoofer channel signal from a sum of all four input signals. The bass will not fade when the signal is faded by the head unit from front to rear.

You may also choose to apply only two channels of input to deliver signal to all five

amplifier channels. To do this, set the “**Input Mode**” switch to “**2 Ch.**” and use only the inputs to channels 1 & 2. In this mode, Channel 3 will operate with the Channel 1 signal and Channel 4 will operate with the Channel 2 signal. The amplifier will automatically combine the main input signals to mono for the Subwoofer Channel.

INPUT VOLTAGE RANGE

A wide range of signal input voltages can be accommodated by the RD900/5's input section (200mV – 8V). This wide range is split up into two sub-ranges, accessible via the “**Input Voltage**” switch:

“**Low**”: for preamp level signals

“**High**”: for speaker level signals

This switch affects all channels of the amplifier equally. The “**Low**” position on the “**Input Voltage**” switch selects an input sensitivity range between 200mV and 2V. This means that the “**Input Sensitivity**” rotary controls will operate within that voltage window. If you are using an aftermarket source unit, with conventional preamp level outputs, this is the position you should select.

The “**High**” position on the “**Input Voltage**” switch selects an input sensitivity range between 800mV and 8V. This is useful for certain high-output preamp level signals as well as speaker level output from source units and small amplifiers. To use speaker level sources, splice the speaker output wires of the source unit or small amplifier onto a pair of RCA cables or plugs, or use the JL Audio ECS Speaker Wire to RCA adaptor (XD-CLRAIC2-SW).

Line output converters are usually not needed with the RD900/5. If you find that the output cannot be reduced sufficiently with a direct speaker level signal applied to the amplifier and the “**Input Voltage**” switch in its “**High**” position, you may use a line output converter or voltage divider to reduce the signal level.

INPUT TYPE

Each pair of stereo output channels includes an “Input Type” switch to configure how the input signals are fed to the outputs.

- Selecting “Stereo” will send signals from both left and right inputs to their respective outputs.
- * Selecting “Mono” will send the signal from the left input (only) to both outputs, without need to use Y-adaptors. This is useful when sending a single mono signal to both outputs of a channel pair or to a bridged channel pair.

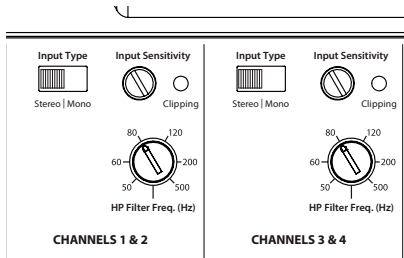

INPUT SENSITIVITY CONTROLS

The control labeled “Input Sensitivity” and “Clipping” LED located in each channel section are used to match the source unit’s output voltage to the input stage of each pair of amplifier channels for maximum clean output. Rotating the control clockwise will result in higher sensitivity (louder for a given input voltage). Rotating the control counter-clockwise will result in lower sensitivity (quieter for a given input voltage.)

To properly set the amplifier for maximum clean output, please refer to Appendix A (page 14) in this manual. After using this procedure, you can then adjust any or all “Input Sensitivity” levels downward if this is required to achieve the desired system balance.

Do not increase any “Input Sensitivity” setting for any channel(s) of any amplifier in the system beyond the maximum level established during the procedure outlined in Appendix A (page 14). Doing so will result in audible distortion and possible speaker damage.

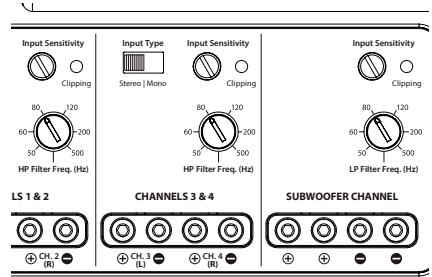

FILTER CONTROLS

Most speakers are not designed to reproduce the full range of frequencies audible by the human ear. For this reason, most speaker systems are comprised of multiple speakers, each dedicated to reproducing a specific frequency range. Filters are used to select which frequency range is sent to each section of a speaker system. The division of frequency ranges to different speakers can be done with passive filters (coils and/or capacitors between the amplifier outputs and the speakers), which are acceptable and commonly used for filtering between mid-range speakers and tweeters. Filtering between subwoofer systems and satellite speaker systems is best done with active filters, which cut off frequency content at the input to the amplifier. Active filters are more stable than passive filters and do not introduce extraneous resistance, which can degrade subwoofer performance.

The active filter built into each channel section of the RD900/5 can be used to eliminate potentially harmful and/or undesired frequencies from making their way through the amplifier sections to the speaker(s). This serves to improve tonal balance and to avoid distortion and possible speaker failure. Correct use of these filters can substantially increase the longevity and fidelity of your audio system.

- 1) **HP Filter Operation:** The RD900/5 employs 12dB per octave high-pass active filters for each pair of main channels (one high-pass filter for each channel) with fully variable frequency selection between 50 Hz and 500 Hz via the “HP Filter Freq. (Hz)” control knob (80 Hz is a good starting point for tuning most systems.)

2) **LP Filter Operation:** The RD900/5 employs a 12dB per octave low-pass active filter for the subwoofer channel with fully variable frequency selection between 50 Hz and 500 Hz via the “**LP Filter Freq. (Hz)**” control knob (80 Hz is a good starting point for tuning most systems.)

REMOTE LEVEL CONTROL (OPTIONAL)

With the addition of the optional Remote Level Control (RBC-1), you can control the subwoofer volume from the front of the vehicle.

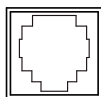

Remote Level Control (RBC-1)



The RBC-1 connects to the jack labeled “**Remote Level Control (RBC-1)**” on the Connection Panel of the amplifier using a standard telephone cable (supplied with the RBC-1). If desired, multiple RD amplifiers can be controlled from a single RBC-1 controller using a single-line, four-wire phone line splitter and multiple phone cables.

When connected to the amplifier, the RBC-1 operates as follows. At full counter-clockwise rotation, the audio of the selected channels will mute completely. At full clockwise rotation the level will be the same as if the RBC-1 was not connected at all. In other words, it operates strictly as a level **attenuator**.

SPEAKER OUTPUTS

The RD900/5's speaker outputs are designed to accept 16 AWG - 8 AWG wire. To connect the speaker wires to the amplifier, first back out the set screws on the top of the terminal block, using the supplied 2.5 mm hex wrench. Strip 1/2 inch (12 mm) of insulation from the end of each wire and insert the bare wire into the terminal block, seating it firmly so that no bare wire is exposed.

While holding the wire in place, tighten the set screw firmly, taking care not to strip the head of the screw.

Each pair of the RD900/5's main channels are designed to deliver power into speaker loads equal to or greater than 2 ohms when using a “stereo” configuration and speaker loads equal to or greater than 4 ohms when using a “bridged” configuration. The subwoofer channel is designed to deliver power into subwoofer loads equal to or greater than 2 ohms.

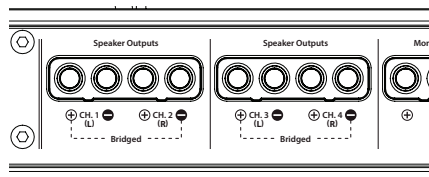

! IMPORTANT

Speaker loads below 2 ohms nominal per channel (or 4 ohms bridged) are not recommended and may cause the amplifier to enter a protection mode.

BRIDGING CONSIDERATIONS

Bridging is the practice of combining the output of two amplifier channels to drive a single load. When bridged, each channel produces signals of equal magnitude, but opposite polarity. The combined output of the two channels provides twice the output voltage available from a single channel. The RD900/5 has been designed for bridging of its main channel pairs without the need for input inversion adaptors.

To bridge a pair of main channels, use the “**Left +**” and “**Right -**” speaker connectors only (the “**Left -**” and “**Right +**” remain unused). Each bridged channel pair will deliver optimum power into a 4 ohm load.

! IMPORTANT

When a pair of the RD900/5's main channels are bridged, they will deliver 200W x 1 into a 4 ohm load or 140W x 1 into an 8 ohm load. Operating a pair of bridged channels into a load lower than 4 ohms is not recommended.

! IMPORTANT

Each channel pair of the RD900/5 is equipped with an “Input Type” switch for use when bridging. Setting the switch to “Mono” will internally connect the left input signal to both the left and right inputs of the bridged channel pair, eliminating the need for Y-adaptors.

When a pair of the RD900/5’s main channels are operating in bridged mode, the output will be in mono (only one channel). This mono channel can contain only left channel information, only right channel information, or the sum of the signals from right and left input channels. In order to achieve one of these options, configure the inputs to that pair of channels in one of these two ways:

1) Left Channel Only or Right Channel Only

Information: If you wish to send a left-only or right-only signal to a pair of the RD900/5’s channels, set the “Input Type” switch for your bridged channel pair to the “Mono” position. Doing so will internally connect a mono signal to both left and right inputs of the bridged channel pair. This option is used when deploying a pair of the RD900/5’s channels to drive left channel speakers only and the other pair of the RD900/5’s channels to drive right channel speakers only.

2) **Left + Right Channel Information:** When bridged and fed by a stereo source signal, set the “Input Type” switch for your bridged channel pair to the “Stereo” position. A bridged pair of the RD900/5’s channels will automatically combine the left and right input signals into a summed mono (left + right) input signal. This option is useful when using a pair of the RD900/5’s channels to drive a subwoofer system or a summed mono center channel.

SUBWOOFER OUTPUTS

The RD900/5’s single subwoofer channel is designed to deliver power into subwoofer loads equal to or greater than 2 ohms. It is rated for 500W into 2 ohms, 325W into 3 ohms and 225W into 4 ohms (Continuous Power, RMS Method).

The RD900/5’s subwoofer outputs are designed to accept 16 AWG - 8 AWG wire. To connect the subwoofer wires to the amplifier, first back out the set screws on the top of the terminal block, using the supplied 2.5 mm hex wrench. Strip 1/2 inch (12 mm) of insulation from the end of each wire and insert the bare wire into the terminal block, seating it firmly so that no bare wire is exposed. While holding the wire in place, tighten the set screw firmly, taking care not to strip the head of the screw.

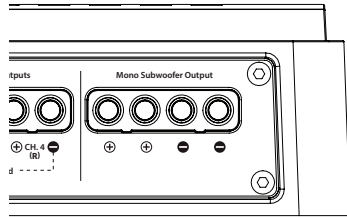

You will notice that there are two “+” positive connections and two “-” negative connections. This is to facilitate multiple subwoofer wiring. **The two positive and two negative connections are connected in parallel inside the amplifier. They are not stereo outputs. Connecting two subwoofers, each to one set of positive and negative terminals, will result in a parallel subwoofer connection. When only connecting one pair of subwoofer wires, it is not necessary to use both sets of connections.**

! IMPORTANT

Subwoofer loads below 2 ohms nominal are not recommended and may cause the amplifier to enter a protection mode.

STATUS LED / PROTECTION CIRCUITRY

There is a bi-color LED light strip on the top surface of the amplifier to indicate the amplifier's operating status. Note: When the amplifier is powering up, the outputs are muted and the light strip will turn red for a 3 seconds.

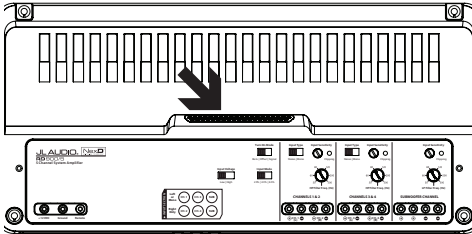

4) LEDs off / Amplifier Shuts Off Unexpectedly

The only condition that will shut down an undamaged RD900/5 completely is if battery voltage or remote turn-on voltage drops below 10 volts. The LED light strip will turn off when this occurs. The amplifier will turn back on when voltage climbs back above 11 volts. If this is happening in your system, have your charging system and power wiring inspected.

For more information on troubleshooting this amplifier, refer to Appendix C (pages 16, 17).

- 1) **Constant Blue:** The amplifier is on and functioning normally, audio output is active.
- 2) **Constant Red:** lights to indicate that the amplifier has exceeded its safe operating temperature, putting the amplifier into a self-protection mode, which mutes the power output of the amplifier. When its temperature returns to a safe level, the red light will return to blue and the amplifier will return to normal operating mode.
- 3) **Momentary Red:** The light strip will turn red for a ½ second and mute the amplifier's output during an over-current condition. It will then attempt to restart (with a blue light). If the condition remains, it will return to red and mute the output again. A continuous over-current condition is displayed with alternating red/blue lights. Because the muting behavior may be very short in duration, it may manifest itself as an audible, repetitive ticking or thumping noise in the output. Over-current conditions can be caused by a speaker impedance lower than the optimum load impedance range for the amplifier or a short-circuit in the speaker wiring. The latter can result from a short circuit between the positive and negative speaker wires or between either speaker wire and the vehicle chassis.

SYSTEM CONFIGURATIONS

The RD900/5 is a very flexible amplifier, well-suited for a multitude of system configurations. In this section, the most likely configurations for a system with a single RD900/5 are explained in detail.

Once you have selected your desired configuration, you can use the amplifier panel drawing on pages 18 & 19 to mark the required switch positions for easy reference.

BI-AMPLIFIED SYSTEMS

Bi-amplified systems are defined as systems in which separate amplifier channels drive low-frequency (LF) and high-frequency (HF) speakers and are separately filtered to send appropriate frequency ranges to each speaker system.

The most common application of bi-amplification in mobile audio is to drive a subwoofer system from one or more amplifiers or channels and component speakers from separate amplifiers or channels.

The RD900/5 can be easily configured to drive a complete bi-amplified system consisting of a subwoofer and four main speakers or a subwoofer and two main speakers.

Bi-Amplified Systems with one RD900/5 driving four main speakers plus subwoofer (5-Channel Mode)

In this configuration, the Main Channels (1&2, 3&4) will drive component speakers (stereo 70W x 4 @ 4Ω) with high-pass filtering. The Subwoofer Channel will drive a subwoofer system (225W x 1 @ 4Ω or 500W x 1 @ 2Ω) with low-pass filtering.

Once the input sections have been configured appropriately (see page 7), go to the “CHANNELS 1 & 2” controls section and select an appropriate “HP Filter Freq. (Hz)” (80-90 Hz is a good starting point). Next, turn your attention to the “CHANNELS 2 & 3” controls section and select an appropriate “HP Filter Freq. (Hz)” (80-90 Hz is a good starting point). Finally, in the “SUBWOOFER CHANNEL” controls section, select a “LP Filter Freq. (Hz)” of 80-90 Hz.

After proper adjustment of the RD900/5’s “Input Voltage” and “Input Sensitivity” controls, you can fine tune filter frequencies and attenuate each channel section to achieve proper balance.

Bi-Amplified Systems with one RD900/5 driving two main speakers plus subwoofer (3-Channel Mode)

In this configuration, “CHANNELS 1 & 2” of the RD900/5 will be bridged to drive the left front component speakers (200W x 1 @ 4Ω) with high-pass filtering. “CHANNELS 3 & 4” will be bridged to drive the right front component speakers (200W x 1 @ 4Ω), also with high-pass filtering. The “SUBWOOFER CHANNEL” will drive the subwoofer system (225W x 1 @ 4Ω or 500W x 1 @ 2Ω) with low-pass filtering. For information on proper bridging techniques, refer to the section titled “Bridging Considerations” in this manual (pages 9-10)

Once the input sections have been configured appropriately (see page 7), go to the “CHANNELS 1 & 2” controls section and select an appropriate “HP Filter Freq. (Hz)” (80-90 Hz is a good starting point). Next, turn your attention to the “CHANNELS 2 & 3” controls section and select an appropriate “HP Filter Freq. (Hz)” (80-90 Hz is a good starting point). Finally, in the “SUBWOOFER CHANNEL” controls section, select a “LP Filter Freq. (Hz)” of 80-90 Hz.

After proper adjustment of the RD900/5’s “Input Voltage” and “Input Sensitivity” controls, you can fine tune filter frequencies and attenuate each channel section to achieve proper balance. Keep in mind that the left and right front speakers will have independent “Input Sensitivity” controls in this configuration, and these need to be carefully matched for proper stereo performance.

SERVICING YOUR JL AUDIO AMPLIFIER

If your amplifier fails or malfunctions, please return it to your authorized JL Audio dealer so that it may be sent in to JL Audio for service. There are no user serviceable parts or fuses inside the amplifier. The unique nature of the circuitry in the JL Audio amplifiers requires specifically trained service personnel. Do not attempt to service the amplifier yourself or through unauthorized repair facilities. This will not only void the warranty, but may result in the creation of more problems within the amplifier.

If you have any questions about the installation or setup of the amplifier that have not been covered in this manual, please contact your dealer or technical support.

JL Audio Technical Support:

(954) 443-1100

9:00 AM – 5:30 PM (Eastern Time Zone)

Monday - Friday

APPENDIX A:

Input Sensitivity Level Setting

Follow the steps below to adjust the input sensitivity of each amplifier channel pair, simply and easily, in just a few minutes to achieve overall system balance.

Necessary Equipment

- CD with a sine-wave test tone recorded at 0 dBfs reference level in the frequency range to be amplified for that set of channels (50 Hz for subwoofer channels, 1 kHz for a midrange application). Do not use attenuated test tones (-10 dB, -20 dB, etc.).
- If your OEM source unit is not equipped with a CD player, you may transfer the test tone to a portable media player or thumb drive and connect to your source unit's auxiliary input. Make sure to disable any EQ/DSP modes on your portable media player during level setting.

The Seven-Step Procedure

- 1) Disconnect the speaker(s) from the amplifier's speaker output connectors.
- 2) Turn off all processing (bass/treble, loudness, EQ, etc.) on the source unit, processors (if used) and amplifier. Set the fader control to center position and the subwoofer level control to 3/4 of maximum (if used to feed the RD900/5).
- 3) Set the "Input Voltage" switch to "Low". Turn all three "Input Sensitivity" controls all the way down.
- 4) Set the source unit volume to 3/4 of full volume. This will allow for reasonable gain overlap with moderate clipping at full volume.
- 5) Verify that you have disconnected the speakers before proceeding. Play a track with an appropriate sine wave (within the frequency range to be amplified by each channel pair of the RD900/5) at 3/4 source unit volume.
- 6) Slowly increase the "Input Sensitivity" control until the "Clipping" LED is solidly lit, indicating maximum, unclipped output. If the "Clipping" LED is solidly lit with the "Input Sensitivity" control turned all the way down, set the "Input Voltage" switch to the "High" position, then slowly increase the "Input Sensitivity" control until the "Clipping" LED is solidly lit.

- 7) Once you have adjusted each channel section on the RD900/5 to its maximum, unclipped output level, reduce the source unit's volume to prevent sudden output bursts and reconnect the speaker(s). Play music and adjust the "Input Sensitivity" controls downward if the amplifier requires attenuation to achieve the desired system balance.

! IMPORTANT

Do not increase any "Input Sensitivity" setting for any amplifier channel or channel pair in the system beyond the maximum level established during this procedure. Doing so will result in audible distortion and possible speaker damage.

It will be necessary to re-adjust the "Input Sensitivity" if any equalizer boost is activated after setting the "Input Sensitivity" with this procedure. This applies to any EQ boost circuit, including source unit tone controls or EQ circuits. EQ cuts will not require re-adjustment.

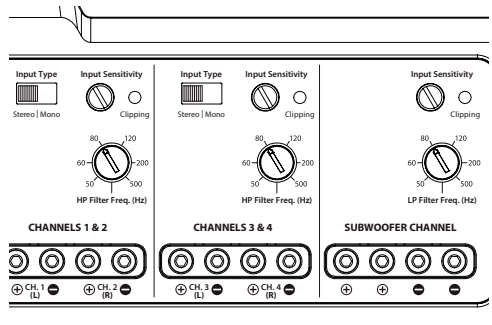

APPENDIX B:

RD900/5 Specifications:

Amplifier Section:

Amplifier Topology: NexD™ Ultra-High Speed Class D

Power Supply: Unregulated MOSFET switching type

Rated Power (Main Channels / Stereo at 14.4V):

70W x 4 @ 4 ohms, 100W x 4 @ 2 ohms

Rated Power (Main Channels / Bridged at 14.4V):

140W x 2 @ 8 ohms, 200W x 2 @ 4 ohms

Rated Power (Subwoofer Channel at 14.4V):

225W x 1 @ 4 ohms, 325W x 1 @ 3 ohms, 500W x 1 @ 2 ohms

Rated Power (Main Channels / Stereo at 12.5V):

60W x 4 @ 4 ohms, 90W x 4 @ 2 ohms

Rated Power (Main Channels / Bridged at 12.5V):

120W x 2 @ 8 ohms, 180W x 2 @ 4 ohms

Rated Power (Subwoofer Channel at 12.5V):

200W x 1 @ 4 ohms, 250W x 1 @ 3 ohms, 350W x 1 @ 2 ohms

S/N Ratio (A-weighted, 20 Hz-20 kHz noise bandwidth):

Main Channels: >104 dB referred to rated power,

>84 dB referred to 1W

Subwoofer Channel: >103dB referred to rated power,

>83dB referred to 1W

Frequency Response:

Main Channels: 12 Hz - 22 kHz (+0, -1dB)

Subwoofer Channel: 10 Hz - 500 Hz (+0, -3dB)

Damping Factor:

Main Channels: >150 @ 4 ohms per ch./ 50 Hz,

>75 @ 2 ohms per ch. / 50 Hz

Subwoofer Channel: >120 @ 4 ohms per ch./ 50 Hz,

>60 @ 2 ohms per ch. / 50 Hz

Input Sections:

No. of Inputs: Three Stereo Pairs

Input Type: Differential-balanced with RCA jack inputs

Input Range: 200mV - 8V RMS

Signal Processing:

Filter Type: Sallen-Key, with continuously variable cutoff frequency selection, defeatable

Ch 1&2: 12dB/oct. High-Pass (50-500 Hz)

Ch. 3&4: 12dB/oct. High-Pass (50-500 Hz)

Sub Ch: 12dB/oct. Low-Pass (50-500 Hz)

Remote Level Control: Via optional, wired RBC-1 remote level controller. Full mute to 0 dB range. (sold separately)

Power Connections:

Recommended Fuse Value: 80A

Minimum Copper Power/Ground Wire : 4 AWG

(Note: Copper Clad Aluminum (CCA) wire is not recommended.)

Dimensions (LxWxH):

14.66" x 6.96" x 2.13" (372mm x 177mm x 54mm)

APPENDIX C: TROUBLESHOOTING

“How do I properly set the input sensitivity on my amplifier?”

Please refer to Appendix A (page 14) to set the input sensitivity for maximum, low-distortion output.

“My amplifier doesn’t turn on.”

Check the fuse, not just visually, but with a continuity meter. It is possible for a fuse to have poor internal connections that cannot be found by visual inspection. It is best to take the fuse out of the holder for testing. If no problem is found with the fuse, inspect the fuse holder.

Check the integrity of the connections made to each of the “+12VDC”, “Ground”, and “Remote” terminals. Ensure that no wire insulation is pinched by the terminal set screw and that each connection is tight.

Check to make sure there is +12V at the “Remote” connection of the amplifier. In some cases, the turn-on lead from the source unit is insufficient to turn on multiple devices and the use of a relay is required. To test for this problem, jump the “+12VDC” wire to the “Remote” terminal to see if the amplifier turns on.

“I get a repetitive ticking or popping sound coming out of the speaker(s).”

Check the speaker wires for a possible short, either between the positive and negative leads or between either speaker lead and the vehicle’s chassis ground. If a short is present, you will experience distorted and/or attenuated output. The “Status LED” will turn amber in this situation. It may be helpful to disconnect the speaker wires from the amplifier and use a different set of wires connected to a test speaker.

Check the nominal load impedance to verify that each channel of the amplifier is driving a load equal to or greater than 2 ohms in stereo mode (4 ohms bridged).

“My amplifier’s output fluctuates when I tap on it or hit a bump.”

Check the connections to the amplifier. Make sure that the insulation for all wires has been stripped back far enough to allow for a good contact area inside the terminal block.

Check the input connectors to ensure that they all are making good contact with the input jacks on the amplifier.

“My amplifier shuts off once in a while, usually at higher volumes.”

Check your voltage source and grounding point. The power supply of the RD900/5 will operate with charging system voltages down to 10V. Shutdown problems at higher volume levels can occur when the charging system voltage (or remote turn-on voltage) drops below 10V. These dips can be of very short duration making them extremely difficult to detect with a common DC voltmeter. To ensure proper voltage, inspect all wiring and termination points. It may also be necessary to upgrade the ground wire connecting the battery to the vehicle’s chassis and the power wire connecting the alternator to the battery. Many vehicles employ small (10 AWG - 6 AWG) wire to ground the battery to the vehicle’s chassis and to connect the alternator to the battery. To prevent voltage drops, these wires should be upgraded to 4 AWG when installing amplifier systems with main fuse ratings above 60A. Grounding problems are the leading cause of misdiagnosed amplifier “failures.”

“My amplifier turns on, but there is no output.”

Check the input signal using an AC voltmeter to measure the voltage from the source unit while an appropriate test tone is played through the source unit (disconnect the input cables from the amplifier prior to this test). The frequency used should be in the range that is to be amplified by the amplifier (example: 50 Hz for a sub bass application or 1 kHz for a full range / high-pass application). A steady, sufficient voltage (between 0.2 and 8.0-volts) should be present at the output of the signal cables.

Check the output of the amplifier. Using the procedure explained in the previous check item (after plugging the input cables back into the amplifier) test for output at the speaker outputs of the amplifier. Unless you enjoy test tones at high levels, it is a good idea to remove the speaker wires from the amplifier while doing this. Turn the volume up approximately halfway. 5 volt AC or more should be measured at the speaker outputs. This output level can vary greatly between amplifiers but it should not be in the millivolt range with the source unit at half volume. If you are reading sufficient voltage, check your speaker connections as explained below.

Check to ensure that the speaker wires are making a good connection with the metal inside the terminal block. The speaker wire connectors are designed to accept up to 8 AWG wire. Make sure to strip the wire to allow for a sufficient connection with the metal inside the terminal block.

INSTALLATION NOTES:

Use this diagram to document your amplifier's switch and control positions.

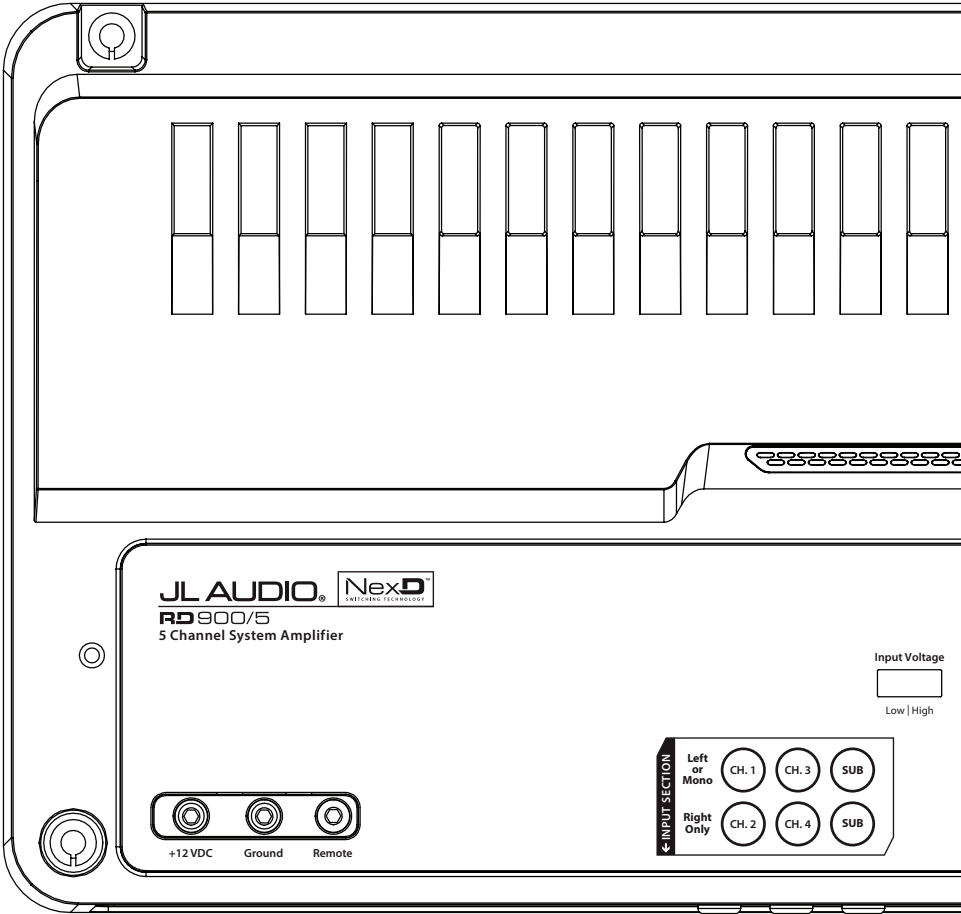

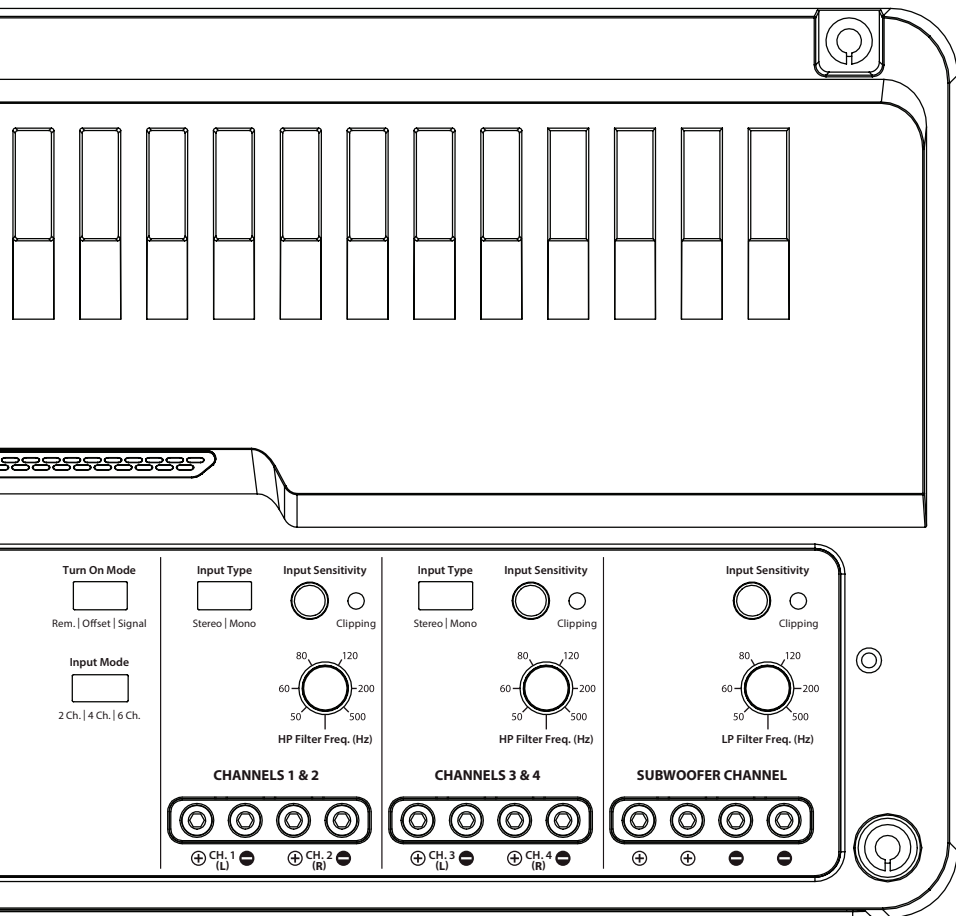

LIMITED WARRANTY - AMPLIFIERS (USA)

JL AUDIO warrants this product to be free of defects in materials and workmanship for a period of two (2) years. The warranty is extended to three (3) years total if installation is performed by an authorized JL Audio dealer using a JL Audio Premium Power Connection System for power wiring.

This warranty is not transferrable and applies only to the original purchaser from an authorized JL AUDIO dealer. Should service be necessary under this warranty for any reason due to manufacturing defect or malfunction, JL AUDIO will (at its discretion), repair or replace the defective product with new or remanufactured product at no charge. Damage caused by the following is not covered under warranty: accident, misuse, abuse, product modification or neglect, failure to follow installation instructions, unauthorized repair attempts, misrepresentations by the seller. This warranty does not cover incidental or consequential damages and does not cover the cost of removing or reinstalling the unit(s). Cosmetic damage due to accident or normal wear and tear is not covered under warranty.

Warranty is void if the product's serial number has been removed or defaced.

Any applicable implied warranties are limited in duration to the period of the express warranty as provided herein beginning with the date of the original purchase at retail, and no warranties, whether express or implied, shall apply to this product thereafter. Some states do not allow limitations on implied warranties, therefore these exclusions may not apply to you. This warranty gives you specific legal rights, and you may also have other rights which vary from state to state.

If you need service on your JL AUDIO product:

All warranty returns should be sent to JL AUDIO's Amplifier Service Facility freight-prepaid through an authorized JL AUDIO dealer and must be accompanied by proof of purchase (a copy of the original sales receipt). Direct returns from consumers or non-authorized dealers will be refused unless specifically authorized by JL AUDIO with a valid return authorization number.

Warranty expiration on products returned without proof of purchase will be determined from the manufacturing date code. Coverage may be invalidated as this date is previous to purchase date. Non-defective items received will be returned freight-collect. Customer is responsible for shipping charges and insurance in sending the product to JL AUDIO. Freight damage on returns is not covered under warranty.

For Service Information in the U.S.A. please call

JL Audio Customer Service: (954) 443-1100

9:00 AM – 5:30 PM (Eastern Time Zone)

JL Audio, Inc

10369 North Commerce Pkwy.

Miramar, FL 33025

(do not send product for repair to this address)

International Warranties:

Products purchased outside the United States of America are covered only by that country's distributor and not by JL Audio, Inc.